

Rev 2015

# EXERTUS<sup>®</sup> SELEN CIRCA

# Operation

# Manual





## List of content

<b>1. INTRODUCTION</b> .....	4
<b>2. TECHNICAL DESCRIPTION</b> .....	5
<b>2.1 Technical Specifications</b> .....	5
<b>2.2 Contents of Packages</b> .....	6
2.2.1 The “Industrial Package” consists of the following .....	6
2.2.2 The “Standard Package” consists of the following .....	7
<b>2.3 Equipment Description</b> .....	7
2.3.1 EXERTUS® CIRCA SELEN 40/80/120 Isotope Projector .....	7
2.3.2 Guide Tube .....	9
2.3.3 Collimator .....	
2.3.4 Winding Mechanism .....	10
2.3.5 Source Assembly Securing Mechanism .....	11
<b>3. OPERATION</b> .....	12
<b>3.1 Personal Safety and Dosimetry</b> .....	12
<b>3.2 Work Site or Location</b> .....	12
<b>3.3 Distance</b> .....	12
<b>3.4 Equipment</b> .....	12
<b>3.5 Functionality Testing of Equipment</b> .....	13
3.5.1 Isotope Projector .....	13
3.5.2 Collimator .....	
3.5.3 Guide Tube .....	13
3.5.4 Winding Mechanism .....	14
<b>4. OPERATING INSTRUCTIONS</b> .....	15
<b>4.1 Step 1 - Positioning of the Isotope Projector</b> .....	15
<b>4.2 Step 2 - Connecting of the Guide Tube</b> .....	15
<b>4.3 Step 3 - Remove the Winding Protective Plug and Connecting the Winding Mechanism</b> .....	17
<b>4.4 Step 4 - Exposing and Retracting of the Source Assembly</b> .....	19
<b>4.5 Step 5 - Confirmation Survey and Locking of the Projector</b> .....	20
<b>4.6 Step 6 - Dismantling of Equipment</b> .....	20



<b>5. SOURCE CHANGING .....</b>	<b>21</b>
<b>5.1 Unloading and Loading of the Projector .....</b>	<b>21</b>
<b>6. INSPECTION .....</b>	<b>23</b>
<b>6.1 Regular Inspection .....</b>	<b>23</b>
<b>6.2 Cleaning of Equipment .....</b>	<b>24</b>
<b>6.3 Female Connector and Ballpoint .....</b>	<b>24</b>
<b>6.4 Annual Certification of the “Go/No-Go” Gauge .....</b>	<b>25</b>
<b>7. MAINTENANCE .....</b>	<b>26</b>
<b>8. EMERGENCIES .....</b>	<b>26</b>
<b>9. PROBLEM SOLVING .....</b>	<b>27</b>
<b>9.1 Fitting of the Emergency Shipping Plug .....</b>	<b>27</b>
<b>9.2 Guide Tube cannot be connected or disconnected .....</b>	<b>27</b>
<b>9.3 Release Lever cannot be operated .....</b>	<b>28</b>
<b>9.4 Source Assembly Securing Mechanism fails to lock .....</b>	<b>28</b>
<b>9.5 Failure of the Three Colour Signal Indicator system .....</b>	<b>28</b>
<b>10. DISPOSAL OF RADIOACTIVE MATERIAL .....</b>	<b>29</b>



## 1. INTRODUCTION

The EXERTUS® CIRCA 40 / 80 / 120 Isotope Projector was designed to be used for Industrial Radiography to determine the internal soundness of materials and structures, without destroying the product's usefulness, thereby assuring the satisfactory performance for which the product was intended. Non-Destructive Testing (NDT) is used in many different spheres of industry, including but not limited to: Oil and Gas, Ship Building, Aviation, Power Generation and General Construction. With Industrial Radiography it is possible to detect defects and determine the integrity of steel in the thickness range 5 mm to 30 mm.

The EXERTUS® CIRCA 40 / 80 / 120 Isotope Projector is a unique and innovative Projector which does not use Depleted Uranium shielding like most conventional Projectors.

The EXERTUS® CIRCA 40 / 80 / 120 Isotope Projector can be used for either normal radiography methods or for radiography where close proximity work is needed. The design incorporates a Directional Tungsten Collimator, which connects directly to the Projector. This reduces the radiation-controlled area significantly and allows operations in the close vicinity to continue during exposure.

The EXERTUS® CIRCA 40 / 80 / 120 Isotope Projector meets most of the international requirements for Radiographic Equipment. It can accommodate Se-75 isotopes with a maximum capacity of 40 Ci / 80 Ci / 100 Ci respectively. The reliability and safe operation of this Isotope Projector depends strongly on your knowledge as a qualified Radiographer. It is the responsibility of the owner to ensure that all personnel using this equipment are appropriately trained by a licensed Institution.

Please ensure that the operator has read and fully understood this Operation Manual before using this equipment. As with most National and International Legal Regulations it is required to use radiation monitoring and/or dosimetric devices capable of measuring in the range 2 mR/hr to 1000 mR/hr. The Radiographer and his/her assistants must also wear a Film Badge, TLD or personal Dosimeter at all times while performing Industrial Radiography. Please note that this dosimetric equipment also needs to be calibrated by an accredited service provider within the required intervals set out by your relevant Authority.

The Radiation Shielding Unit of this Projector is made from Tungsten and therefore it can be shipped as normal cargo when the Projector is not loaded with a Sealed Radioactive Source. However, if loaded with a Sealed Radioactive Source, all National and International Regulations with regard to Transport and Storage of Radioactive material must be adhered to at all times.

Whenever this Projector and accompanying equipment are used it is strongly advised that all requirements are followed and applied as laid out in this Operating Manual. All regulations regarding Radiation Safety must also be adhered to at all times!

## 2. TECHNICAL DESCRIPTION

### 2.1 Technical Specifications

# EXERTUS<sup>®</sup> CIRCA SELEN 40/80/120

<b>Authorized contents</b>	<b>Se-75 under special form</b>
<b>Maximum activity</b>	<b>40 / 80 / 100 Ci or 1.48 TBq / 2.96 TBq / 3.7 TBq</b>
<b>Maximum Surface dose rate</b>	<b>200 mR/hr (2 mSv/hr)</b>
<b>Dimensions of Projector</b>	<b>203 mm (L) x 110 mm (W) x 191 mm (H)</b>
<b>Weight of Projector</b>	<b>8.4 kg / 8.8 kg / 9 kg</b>
<b>Shielding material</b>	<b>Tungsten encased in Stainless Steel housing</b>
<b>Winding Mechanism length:</b>	<b>10 m standard. (Specials made to order)</b>
<b>Guide Tube length</b>	<b>2.1 m standard. (Specials made to order)</b>
<b>Material thickness range</b>	<b>5 mm – 30 mm (Steel)</b>

The EXERTUS® CIRCA 40 / 80 / 120 Isotope Projector meets the requirements of НП-053-04 and IAEA, Vienna, 1996, for packaging type B(U) and is ISO3999:2004 compliant. Transportation of radiation heads with radioactive sources can be carried out by any source of transportation following the rules of safety for transportation of radioactive goods Class 7, on transport category “III-yellow», observing norms of safety stated in “Rules of security during transportation of radioactive materials (NP-053-04)”.

## 2.2 Contents of Packages

### 2.2.1 The “Industrial Package” consists of the following:

- The CIRCA 40 / 80 / 120 Isotope Projector including Source Holder (Figure 10)
- EXERTUS Pistol Grip Winding Mechanism (Figure 6)
- EXERTUS Guide Tube.
- Tungsten Directional Collimator 60°
- Guide Tube Coupling
- Source Terminal 65 mm
- EXERTUS Coupling Spanner
- Go/No-Go Gauge (Figure 11)
- Transportation Box
- Operation Manual

## 2.2.2 The “Standard Package” consists of the following:

- The CIRCA 40 / 80 / 120 Isotope Projector including Source Holder (Figure 10)
- Guide Tube Coupling
- Go/No-Go Gauge (Figure 11)
- Operation Manual

**Nota:** The Projector package doesn't include the Sealed Radioactive Source. The Sealed Radioactive Source is supplied according to individual order following the Sealed Radioactive Source Order procedure set out by the relevant Authorities.

## 2.3 Equipment Description

### 2.3.1 Isotope Projector EXERTUS® CIRCA SELEN 40/80/120

The digits in brackets refer to Figure 4.

The Projector consists of the following basic parts: The Radiation Shielding Unit (5), made of Tungsten encased in a stainless steel housing, side Flanges (1, 7, 13) a Handle (2), two Foot Pieces (8), Source Assembly Securing Unit (10, 12) and front and rear Dust Covers (6, 11). The Front Dust cover is locked in place by a Thumbscrew (3). The position of the Source Assembly (9) and Sealed Radioactive Source can also be seen.

The operating principle of the Projector is based on the exposure of a Radioactive Isotope, by means of a Winding Mechanism, out of the Projector, directly into the Collimator or through the Guide Tube to the point of exposure and back into the Projector into its secured position.

El Proyector solo puede ser liberado cuando ambos, el Telemando y el Tubo  
The Projector can only be operated when both the Winding Mechanism and Collimator or Guide Tube are properly connected.

The Projector is designed with an automatic Source Assembly Locking Mechanism, incorporating a Three Colour Signal Indicator System, ensuring that the operator has a visual indication of the position of the Source Assembly at all times.

**Green Signal** : Source Assembly is secured and the Projector is locked (Figure 1).

Figure 1



**Yellow Signal** : Projector is unlocked and Source Assembly Locking Mechanism is ready to be released (Figure 2).

Figure 2



**Red Signal** : Source Assembly Locking Mechanism is released and ready to expose (Figure 3.)

Figure 3



Figure 4

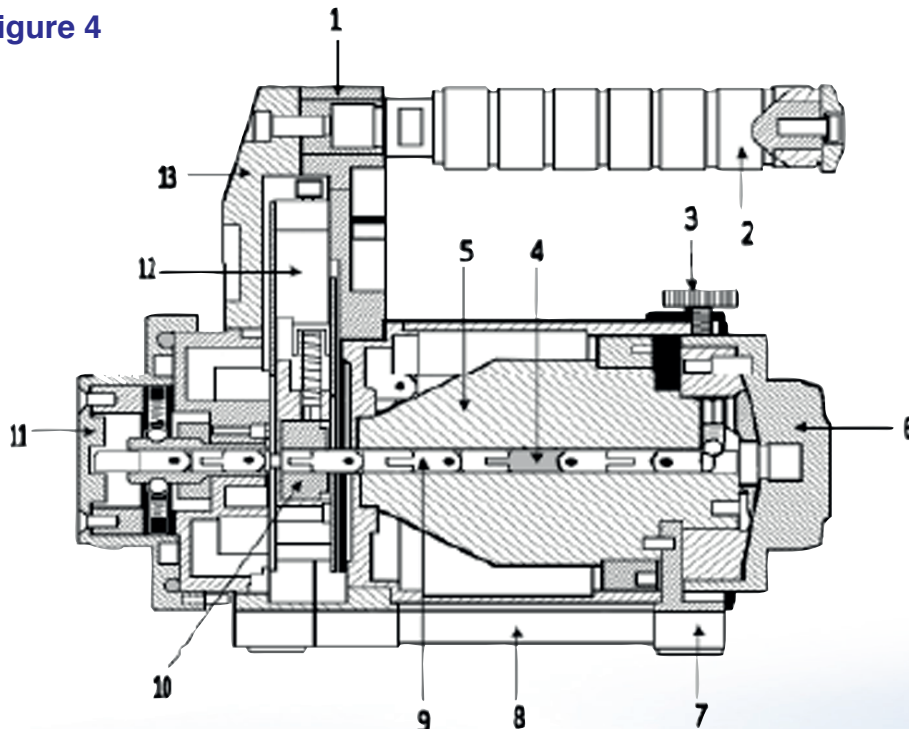

The Projector nameplate contains the following information:

- Radiation hazard sign according to «Nuclear material transportation regulation» IAEA. Vienna 1996
- Word «**RADIOACTIVE**» with letter height not less than 10 mm
- Model of the Isotope Projector (**EXERTUS<sup>®</sup> CIRCA 40 / 80 / 120**)
- The types **Radioactive Sources** used
- **Nominal activities of the sources**
- **Shielding material and its weight**
- Word «**Type B(U)**»
- **Number of the international standard with year of edition (national standard)**
- **Identification sign established by authorized body**
- **Factory number and date of manufacturing**
- **Weight of complete Projector**

### 2.3.2 Collimator

The Collimator consists of the following parts:

- A Tungsten Insert with a 60° aperture (1) encased in a Stainless Steel housing (7).
- The Tungsten Insert is supported with a Tungsten Cap (4) which is held in place by a Knurled Nut (2).
- The center of the aperture is indicated with a red line on the Tungsten.
- Insert (See Figure 5.1 below).
- These two components are lined up with each other by means of two Pins (9), in order to ensure correct alignment with regards to the center of the aperture.
- The Tungsten Insert is equipped with a Tungsten Nut (3) that enables the user to adjust the aperture to the desired position. It is then locked in place by tightening the Knurled Nut (2).
- A Stainless Steel Source Channel (5).
- Aperture.
- Locating and Locking Slot.

Figure 5

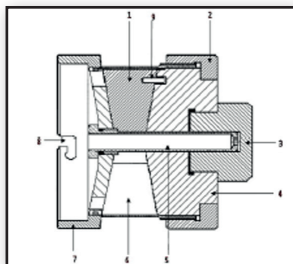
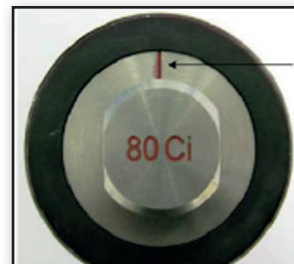

Figure 5.1



### 2.3.3 Guide Tube

The Guide Tube is used to guide the Source Assembly to the radiographic focal point where the Source Terminal and/or Collimator are securely attached. The Guide Tube consists of the following basic parts: Guide Tube Coupling, Guide Tube and Source Terminal.

Upon connecting the Guide Tube to the Projector, the Guide Tube Coupling releases one of the Source Assembly Securing Mechanisms.

The Guide Tube must always be attached to the Projector prior to connecting the Winding Mechanism

### 2.3.4 Winding Mechanism

The Winding Mechanism is used to convey, from a safe distance, the Source Assembly out of the Projector through the Guide Tube, into the Source Terminal and/or Collimator and back into the Projector after exposure. The Winding Mechanism consists of the following parts: Pistol Grip or Reel, Gearbox, Flexible Drive Hoses (x2), Coupling and Drive Cable with Ballpoint Connector.

The Gearbox consists of the following basic parts: Crank Handle, Lid, Sealed Bearings (x2), Drive Gear, Liner, Gearbox Housing and Guide Nipples (x2).

Figure 6

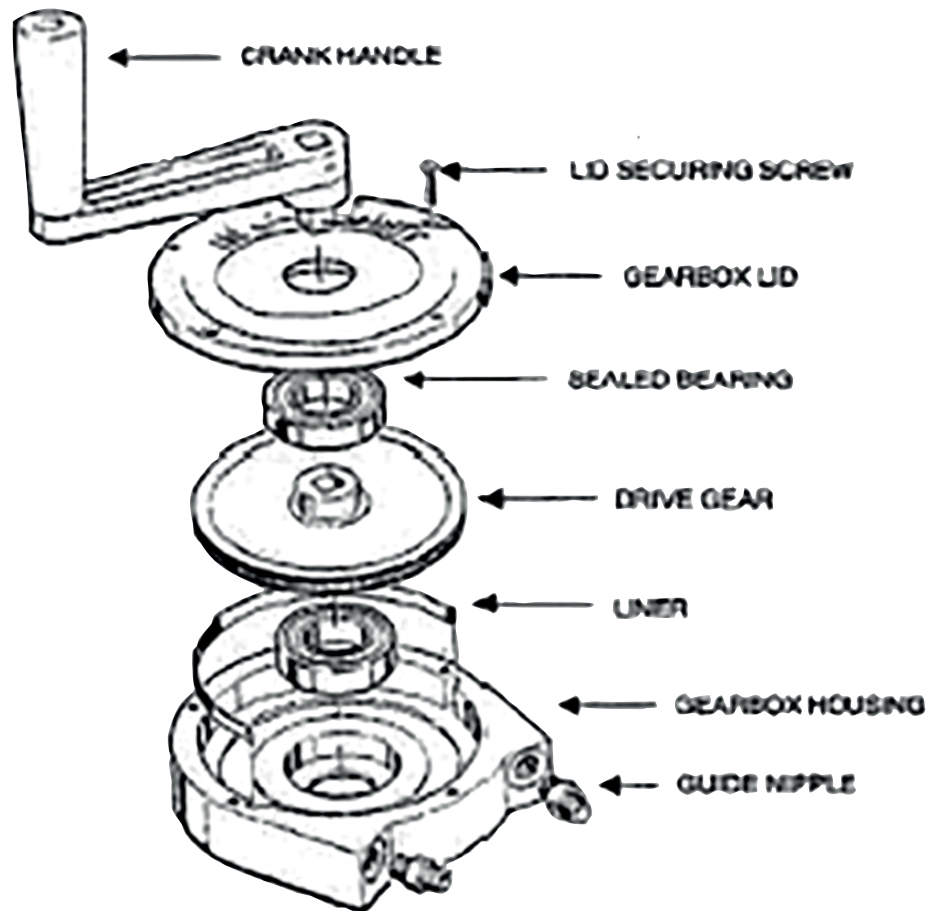

Upon connecting the Winding Mechanism to the Projector, the Winding Mechanism Coupling releases one of the Source Assembly Securing Mechanisms.

### 2.3.5 Source Assembly Securing Mechanism

The Source Assembly Securing Mechanism is designed in such a way that it requires three independent safety devices to be activated / connected before the Projector can be operated and the Source Assembly moved out of its secured position to the point of exposure.

The following connections need to be properly secured before any radiography can take place:

1. Collimator or Guide Tube to the Isotope Projector .
2. Drive Cable Ballpoint to the Source Assembly.
3. Winding Mechanism Coupling to the Projector.

**IMPORTANTE: These three connections should always be done in this sequence when connecting and in reverse for disconnecting**

## 3. OPERATION

Before operating this equipment it is of utmost importance to take note of the following safety precautions.

### 3.1 Personal Safety and Dosimetry

The radiographer and all assistants are required to wear a TLD, pocket dosimeter or suitable monitoring device with a range of 0 – 200 mR/hr (0 – 2 mSv/hr) while work is performed. A Radiation Survey Meter, capable of measuring in the range 2 mR/hr – 1000 mR/hr (0.02 mSv/hr – 10 mSv/hr) must also be used at all times. Some local authorities may also require you to wear a direct reading dosimeter or EPD (Electronic Personal Dosimeter).

### 3.2 Work Site or Location

Always ensure that Industrial Radiography only takes place in a properly secured and restricted area with all appropriate barriers and warning signs required by local regulations in place.

### 3.3 Distance

As the radioactive source emits high levels of radiation once it is out of its secured position, it is very important to keep the distance between the radiographers and the point of exposure as far as possible. This can be achieved by the correct layout of the Winding Mechanism with regard to the Isotope Projector

### 3.4 Equipment

Utmost care should be taken to prevent the accidental dropping or mishandling of the Isotope Projector. Upon set-up of the radiographic system care should be taken to safely secure all of the components, including the Guide Tube and Collimator. Special attention should be paid to this when working overhead or in elevated positions.

## **3.5 Control de Funcionamiento del Equipamiento**

## **3.5 Functionality Testing of Equipment**

It is the responsibility of the operator to perform the following daily functionality tests prior to any work being done.

### **3.5.1 Isotope Projector**

- 1. The Isotope Projector cannot be unlocked without the appropriate key.**
- 2. The Source Assembly Securing Mechanism cannot be released without the Guide Tube being properly connected**
- 3. The Source Assembly Securing Mechanism cannot be released without the Winding Mechanism being properly connected**
- 4. All Protective caps are in place and in good working condition**
- 5. The Source Assembly Female Connector passes the Go/No-Go test described in Chapter 6**
- 6. All required identification labels and warning signs are attached to the Projector as required by the relevant local authority**

### **3.5.2 Collimator**

- 1. The Collimator has all parts as described in Chapter 2.**
- 2. There is no damage or excessive wear to the Locating and Locking Slots (8).**
- 3. The Source Channel is tightly secured.**

### **3.5.3 Guide Tube**

- 1. The Coupling is not damaged or severely worn, is properly attached to the Guide Tube and can be connected to the Projector safely.**
- 2. The Source Terminal is not damaged or worn in any way, including the threads on both the Source Terminal as well as its mating female thread on the Guide Tube.**
- 3. There is no dent, crack or kink or damage to the Guide Tube.**

### 3.5.4 Winding Mechanism

1. The ballpoint passes a Go/No-Go test as described in Chapter 6, and is still properly crimped to the Drive Cable
2. There is no damage or excessive wear to the Drive Cable or Ballpoint whatsoever.
3. The Winding Mechanism Coupling is not damaged or severely worn and can be properly attached to the Isotope Projector after connecting the Ballpoint to the Source Assembly Female Connector.
4. The Drive Hoses have no permanent bend, cut, dent or damage.
5. The Drive Cable does not slip over the Gear.
6. The Drive Cable moves freely through the Drive Hoses when winding.
7. Presence of Protective Plug fixed to the Winding Mechanism.

**IMPORTANT: This equipment must not be used under any circumstances if all of the above criteria are not met. It must be taken out of service and sent back to the manufacturer or authorized service agent for the necessary maintenance / repairs to be done. It is prohibited to use defective equipment, which could lead to an accident, incident or loss.**

## 4. OPERATING INSTRUCTIONS

It is important that the following steps are performed accordingly, and in the exact sequence as set out below.

**Step 1 - Positioning of Isotope Projector**

**Step 2 - Connecting of the Guide Tube**

**Step 3 - Remove the Winding Protective Plug and Connecting the Winding Mechanism**

**Step 4 - Exposing and Retracting the Source Assembly**

**Step 5 - Confirmation Survey and locking of the Projector**

**Step 6 - Dismantling of equipment**

### 4.1 Step 1 – Positioning of the Isotope Projector

Where possible always place the Isotope Projector on a level surface. In the event where this is not possible or in the case of overhead or elevated work, secure the Isotope Projector with suitable clamps, straps or similar to prevent it from falling

### 4.2 Step 2 – Connecting of the Collimator and the Guide Tube

#### 4.2.1 Collimator

Ensure that the Projector is properly locked. Remove the Front Dust Cover (6) from the Projector by loosening the Thumbscrew (3) and the rotating the Dust Cover clockwise until it can be pulled out of the Projector. Now, align the Locating and Locking Slots horizontally with its mating Pins inside the Projector. Insert the Collimator and rotate the Collimator completely anti-clockwise and lock it in place by tightening the Thumbscrew.

#### 4.2.2 Guide Tube

Ensure that the Guide Tube to be used has been inspected and meets all criteria set out in the daily inspection section in chapter 3. Secure the Guide Tube Source Terminal, with the Collimator correctly attached (if used), to the point of radiographic exposure by means of a Magnetic Base Stand or similar device.

Lay out the Guide Tube, with no bend with a radius less than 0.3m, to ensure the Source Assembly can move freely through the Guide Tube without any restrictions. To prevent the Guide Tube being damaged whilst in use, ensure that it is not laid out in walkways, driveways or where there is a danger of falling objects. Also avoid contact with heated surfaces at all times.

**Important:** As there are various lengths of Guide Tube available always ensure that the selected Guide Tube is shorter than the length of the Winding Mechanism Hose to prevent the Drive Cable running off the Gear.

Ensure that the Guide Tube Connecting Flange is tightly secured to the Guide Tube and proceed as follows:

Ensure that the Projector is properly locked. Remove the Front Dust Cover (6) from the Projector by loosening the Thumbscrew (3) and the rotating the Dust Cover clockwise until it can be pulled out of the Projector. Now, align the Locating and Locking Slots horizontally with its mating Pins inside the Projector. Insert the Guide Tube Connecting Flange and rotate the Flange completely anti-clockwise and lock it in place by tightening the Thumbscrew.

**Important:** Be careful not to over-tighten the Thumbscrew as this will cause damage to the Collimator and may prevent the Collimator or Flange to be fitted and removed easily

### 4.3 Step 3 – Connecting of the Winding Mechanism

Ensure that the Winding Mechanism to be used has been inspected and meets all criteria set out in the daily inspection section in Chapter 3.

Remove Rear Protective cap and secure it by inserting it into its holder. Lay out the Winding Mechanism Hoses as straight as possible ensuring maximum distance between the Projector and operator.

To prevent the Winding Mechanism Hoses being damaged whilst in use, ensure that they are not laid out in walkways, driveways or where there is a danger of falling objects. Also avoid contact with heated surfaces at all times.

Remove the Protective Plug. Expose approximately 200 mm of the Drive Cable by turning the Winding Mechanism Handle in a clockwise direction. Insert the Ballpoint Connector into the Source Assembly Female Connector from a vertical position, keeping the Drive Cable straight at all times. In this position, move the Ballpoint Connector towards the back of the Female Connector and swivel it downwards (90°) to a horizontal position. See Figure 7 below.

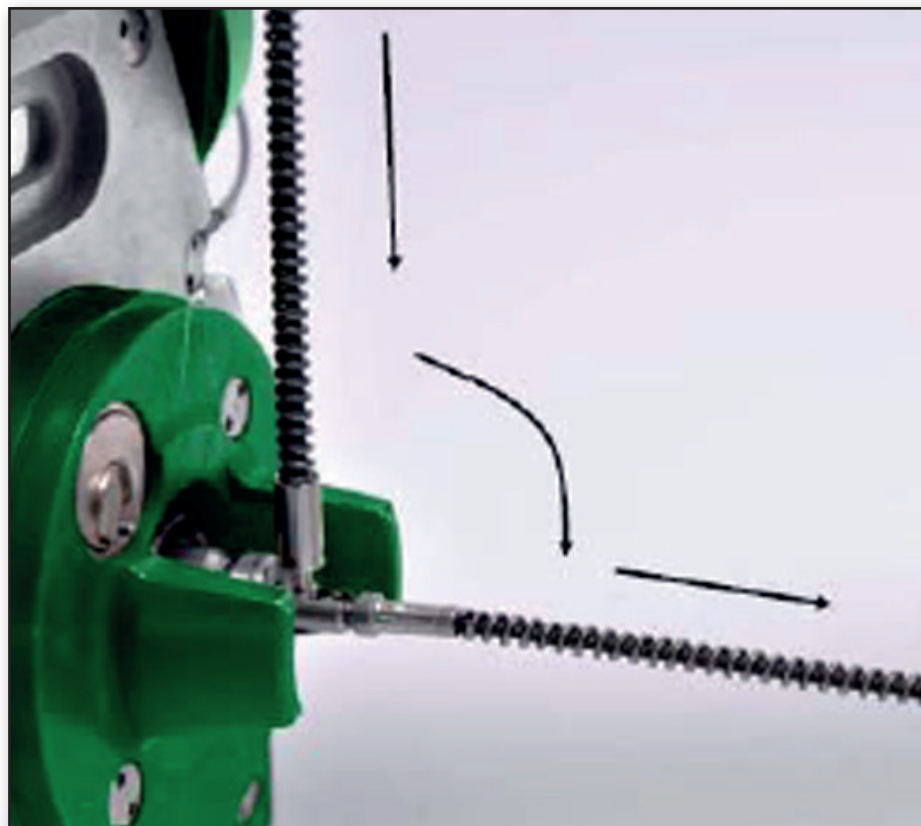

Figure 7

Retract the Drive Cable by turning the Winding Mechanism Handle in an anti-clockwise direction until the Winding Mechanism Coupling is against the Projector.

Now, pull back the outer sleeve of the Coupling (Figure 8) and insert the Coupling over the Projector Fitting .



Figure 8

Once the outer sleeve is released, the Coupling will connect automatically (Figure 9).



Figure 9

Check manually if this is connected properly. If not, check that the Ballpoint Connector is properly connected to the Source Assembly Female Connector.

#### **4.4 Step 4 – Exposing and retracting of the Source Assembly**

**Before exposing, ensure that the following is in place: radiation control area barriers, no person/s is inside these barriers and all legislative requirements are in place and meet.**

**Insert the key into the Lock and unlock the Projector. The Source Assembly Indicator shifts from Green to Yellow. Now, press down on the Release Lever Assembly until the Locking Slide is automatically sustained in the open position. The Source Assembly Indicator shifts from Yellow to Red. The Projector is now ready for operation.**

**Rapidly turn the Winding Mechanism Crank Handle in a clockwise (OUT) direction in order to move the Source Assembly to point of radiography. Ensure not to use excessive force and to slow down prior to reaching the Source Terminal.**

**When the Source Assembly is ejected from the Projector it will be observed that the Survey meter reading increases dramatically from a Background Radiation level to a High Radiation level. This should decrease sharply once the Source Assembly enters the Collimator (if used) and should remain constant throughout the exposure. The same principle will apply in reverse when the Source Assembly is retracted.**

**Once the desired exposure time is reached the Source Assembly is retracted by rapidly turning the Winding Mechanism Crank Handle in an anti-clockwise (IN) direction. Ensure not to use excessive force and to slow down as the Source Assembly enters the Projector.**

**The Source Assembly Locking Mechanism will automatically lock the Source Assembly in the secured position. The Source Assembly Indicator now shifts from Red to Yellow.**

#### 4.5 Step 5 - Confirmation survey and locking of the Projector

Approach the Isotope Projector cautiously while observing the Survey Meter. Ensure that the Source Indicator is yellow when approaching the Projector. Measure the Dose Rate at the surface of the Projector, the reading obtained should be the same as the reading observed prior to the exposure. If this is not the case treat the situation as an emergency and follow the emergency instructions according to Chapter 7. If the reading is satisfactory press the Corbin Lock in until it locks in place. The Source Indicator will now change from yellow to green. Remove the key and store it in a safe place

#### 4.6 Step 6 – Dismantling of equipment

The dismantling of equipment must always take place in reverse sequence to the connecting procedure.

Remove the Winding Mechanism Coupling by pulling back on the outer sleeve. Expose approximately 200 mm of the Drive Cable. Now, follow the Ballpoint connection procedure in reverse sequence. Retract the exposed Drive Cable back into the Hose ensuring that there is approximately 50 mm of Drive Cable left exposed. Don't forget to replace the Protective Plug. This will automatically retract as the Winding Mechanism Hoses are rolled up, with no radius less than 300 mm, for transport purposes. Replace the rear Protective Cap of the Projector. Remove the Guide Tube Coupling by pressing down on the Locking Pin. Now, pull the Guide Tube Coupling out of the Projector. Again press down the Locking Pin and plug in the spring-loaded front Protective Cap.

**IMPORTANT:** Although it is highly unlikely for the Sealed Source to be contaminated, the Winding Mechanism and Guide Tube must always be monitored for excessive radiation after use. Always ensure that the Projector is locked prior to transporting or moving. Never leave the Winding Mechanism coupled when transporting or moving the Projector. This could cause damage to the Projector and/or a malfunction, possibly compromising the safety system of the unit. This could lead to a Radiation Emergency.

## 5. SOURCE CHANGING

The Source Assembly, loaded with the Sealed Radioactive Source , can be interchanged either on-site in a controlled environment, or at OSERIX's or its distributor's facilities to ensure that the Projector is loaded with the required isotope for the application.

The new Source Assembly may be transported in a multi-channel Transport Container that will always have an empty channel, into which the old Source Assembly can be transferred, in order to load the Projector with the new Source Assembly.

The old Source Assembly will then be shipped back to OSERIX or its local distributor for disposal of the decayed radioactive source and for inspection and re-certification of the Source Assembly. After certification the Source Assembly is ready to be re-loaded.

**IMPORTANT:** The Source Change procedure may only be carried out by properly trained and authorized persons under constant dosimetric control.

### 5.1 Unloading and Loading of the Projector

1. Align the Projector and Transport container adjacent to one another.
2. Connect the Transfer Tube, accompanying the Transport Container, to the Projector.
3. Connect the Winding Mechanism to the Projector as described in Chapter 4.
4. Prepare the Transport Container as described in the container's operating instructions.
5. Connect the other end of the Transfer Tube to the Transport Container as described in the container's operating instructions.
6. Once the Transport Container is ready, proceed to eject the Source Assembly as described in Chapter 4, Step 4.
7. Use a survey meter to confirm that the Source Assembly is secured inside the Transport Container.

8. Lock the Source Assembly as described in the container’s operating instructions and disconnect the Drive Cable from the Source Assembly.
9. If the Projector is not to be re-loaded with another Source Assembly, it is necessary to connect a “Dummy Source Assembly” to the Drive Cable in order to disconnect the Winding Mechanism and lock the Projector.
10. If the Projector is to be re-loaded proceed with step 12. If not, continue with Step 14.
11. Connect the Drive Cable to the required Source Assembly, currently still secured inside the Transport Container.
12. Connect the Transfer Tube to the Transport Container as described in Step 5.
13. Retract the Source Assembly as described in Chapter 4, Step 4.
14. Lock and disengage the equipment as described in Chapter 4, Step 6.

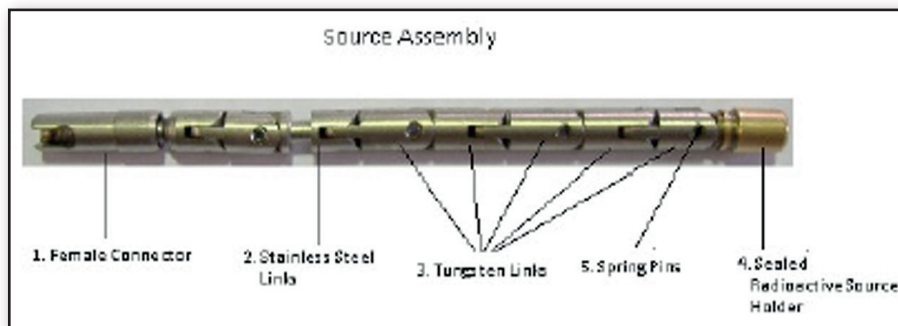

Figure 10

The complete Source Assembly consists of the following components:

1. Female Connector
2. Stainless Steel Links
3. Tungsten Links
4. Sealed Radioactive Source Holding Capsule
5. Spring Pins

## 6. INSPECTION

Please pay special attention to this Chapter. It is of utmost importance that all inspection procedures are followed and adhered to in full.

Failing to do so could result in premature equipment failure, thus compromising safety and productivity.

**IMPORTANT:** In addition to the inspections described below and where specified by National Regulations, the owner of this equipment is required to send the equipment for Regularity Certification Inspection at the specified intervals.

### 6.1 Regular Inspection

Regular Inspection of the complete Industrial Radiography package is important in order to detect possible defects and/or equipment damage.

The findings of each regular inspection must be recorded. If any equipment fails to comply with all the criteria in the checklists, the equipment is no longer fit for field use.

The equipment should be taken out of service immediately, labeled accordingly and returned to the manufacturer or Authorized Service Center for the necessary repairs and maintenance

## 6.2 Cleaning of Equipment

The Projector, Winding Mechanism and Guide Tube need regular cleaning. The intervals between cleaning will depend on the environmental conditions that the equipment operates in.

When the equipment is used in areas where dust, sand, mud or moisture is present more frequent cleaning will be required.

Before every use it is important to ensure that both the working ends of the Projector are entirely free of dirt.

Also check that the Guide Tube and Winding Mechanism are clean. Only use cloths that are lint free, wetted with alcohol or Industrial Cleaning Product to clean your equipment.

**IMPORTANT: Under no circumstances should any of the equipment be cleaned with solvents, degreasing fluids or any other liquid. Do not lubricate the equipment with oil as dirt will stick to the oil and get transferred into the Winding Mechanism and Projector.**

Clean the projector using a soft bristle brush and alcohol (or Industrial Cleaning Product) and allow drying thoroughly.

If the Drive Cable needs to be cleaned, it will have to be completely wound out of the Drive Hoses and then washed with alcohol (or Industrial Cleaning Product) and allowed to dry.

The Guide Tube can be rinsed out with alcohol (or Industrial Cleaning Product).

If the Projector needs to be partly dismantled in order to eliminate all dirt it must be sent back to the manufacturer or Authorized Service Center.

## 6.3 Female Connector and Ballpoint

The safe working of the Projector relies heavily on the soundness of the connection between the Female Connector and the Ballpoint. Therefore it is very important to monitor these two components for damage and wear and tear.

Permissible tolerances can be checked using the supplied “Go/No-Go” Gauge as follows:

Figure 14: «Go/No-Go» Gauge

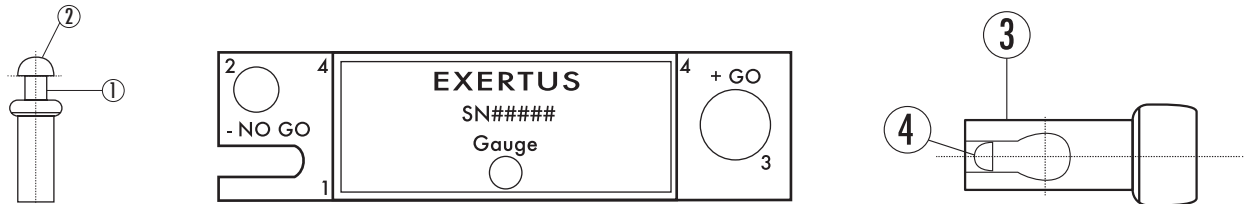

The Gauge has two parts, one side is marked Go and the other side is marked No-Go.

Use the above diagram to test the various elements of these components by using their corresponding numbers on the Gauge.

- The neck (1) of the Ballpoint must not fit into the slit.
- The ball (2) of the Ballpoint must not pass through the hole.
- The Female Connector (3) must pass through the hole.
- The slot width on both sides of the gauge must be used test the slot of the Female Connector (4). The “Go” side must fit in the slot and the “No-Go” side must not fit in the slot.

If Ballpoint or Female Connector fails any of the above tests they should immediately be taken out of use for replacement.

## 6.4 Annual Certification of the “Go/No-Go” Gauge

As this gauge is an inspection tool, it is required to pass an annual Certification Test to ensure that all elements of the gauge comply with all tolerances set out by the manufacturer. When received, the gauge is delivered with a valid Certification Test Report, thereafter the gauge has to be sent back to the manufacturer or accredited service provider for future certification

## 7. MAINTENANCE

In order for the EXERTUS® DUAL 120 Projector to maintain its high safety standards, it is important that maintenance be performed by the manufacturer or Accredited Service Center at regular intervals.

This maintenance should be performed annually or immediately after any repairs were carried out on the projector.

It is strongly recommended that Winding Mechanisms and Guide Tubes be sent in together with the Projector for maintenance and inspection.

## 8. EMERGENCIES

Emergency situations occur during operation when the Source Assembly fails to fully return to the secured position within the Projector, causing high levels of radiation to be emitted.

Since a confirmatory survey is required after every exposure, it would immediately become apparent when such an emergency does occur due to the higher than average reading obtained during the survey procedure.

When such a situation arises the following steps are to be taken:

**DO NOT PANIC – REMAIN CALM!**

Evacuate the area immediately to a distance that does not pose such a significant risk of exposure. Establish and adjust the Restricted Area Boundary to ensure that the measured dose rate does not exceed 2 mR/hr (20  $\mu$ Sv/hr) at the boundary lines. Do not allow anyone to enter this area

**NOTIFY THE RADIATION PROTECTION OFFICER IMMEDIATELY**

Do not attempt to retrieve the Source Assembly, this should only be done by the RPO as they have received special training in this regard. Maintain security of this area until the RPO arrives.

**WARNING: Never attempt to pick up or touch an unshielded Source Assembly without the appropriate equipment. Never allow the Source Assembly to have any contact with the human body. A Source Assembly in its unshielded state can cause serious injury or even death to anyone exposed to it, even for a short duration of time**

## 9. PROBLEM SOLVING

During operation, if the following situations occur, identify the situation with one of the below and follow the instructions as provided. If the situation cannot be resolved through this, the Emergency Shipping Plug must be fitted as described below, and the equipment must be sent back to the manufacturer or authorized service center for inspection and repairs as required.

### 9.1 Collimator/Guide Tube Connecting Cap cannot be connect or disconnected

#### Situation

The Collimator / Guide Tube Connecting Flange cannot be inserted or rotated to connect / disconnect.

#### Actions

- Check that the Corbin Lock is completely locked. If the Lock is not completely unlocked only approximately 2mm of the lock will protrude from the body (Figure 12).
- When the Lock is completely unlocked approximately 9mm of the Lock will protrude from the body (Figure 13). If the lock is not completely locked the Collimator / Guide Tube Connecting Flange cannot be connected or disconnected.

Figure 12



Figure 13

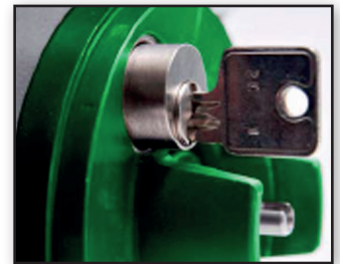

### 9.2 Release Lever cannot be operated

#### Situation

The Release Lever cannot be pressed down to release the Source Assembly Securing Mechanism.

#### Acciones

- Check that the Collimator / Guide Tube Connecting Flange and Winding Mechanism are correctly connected as described in chapter 4..
- Also ensure that the Corbin Lock is fully unlocked.

### 9.3 Source Assembly Securing Mechanism fails to lock

#### Situation

After retracting the Source Assembly and verifying with a survey meter that the Source Assembly is indeed back in the shielded position, the Source Assembly Securing Mechanism fails to engage and lock the Source Assembly in the secured position.

#### Actions

- Disconnect the Winding Mechanism coupling from the Projector and manually pull back on the drive cable in an attempt to activate the Source Assembly Securing Mechanism.
- Move the Source Assembly back and forward, but not more than 10 mm, in an attempt to activate the Source Assembly Securing Mechanism. Be sure to do this under monitoring to ensure that the dose rate does not exceed 2 mR/hr (20  $\mu$ Sv/hr).
- If all of the above fails to activate the Source Securing Mechanism, the Winding Mechanism must be removed as described in Chapter 4.
- As the Projector is designed with an additional Source Assembly Retaining Mechanism (The Source Assembly can only be pushed out using force and will not fall out of the Source Channel, if it is fully retracted, during normal transport) The Projector must be shipped back to the manufacturer or Authorized Maintenance Centers

### 9.4 Failure of the Three Colour Signal Indicator system

#### Situation

The Colour Signal displays Yellow but the Survey meter records an elevated radiation level (above 2 mR/hr). Thus, the Signal Indicator was activated prior to the Source Assembly being in the shielded position.

#### Actions

- Establish the position of the Source Assembly using an appropriate survey meter. Put the necessary measures in place to shield the source.
- Press the Release Lever down and suspend it in the open position.
- Retract the Source Assembly using the Winding Mechanism.
- Verify with the survey meter that the Source Assembly is in the secured position and approach the Projector.
- Remove the Winding Mechanism Coupling, expose approximately 200 mm of the Drive cable and manually pull back on the cable until the Female connector protrudes from the projector by about 10 mm.
- Unblock the release Lever and allow the Source Assembly Securing Mechanism to lock the Source Assembly in the secured position.
- The Signal Indicator should now display Yellow



## 10. DISPOSAL OF RADIOACTIVE MATERIAL

Whenever the Projector is reloaded with a new Source Assembly it is the owner's responsibility to send the old Source Assembly back to OSERIX or its distributor's facilities for disposal of the source, re-certification of the Source Assembly and loading of a new source.

The Projector shielding is of Depleted Uranium which is also required to be disposed of in the proper manner. OSERIX can also provide such a disposal service. After disposal OSERIX will issue a "Radioactive Material Disposal Certificate".



## Notes

A series of 20 horizontal dotted lines for taking notes.



POWER OF CONFIDENCE

Contact Details:

**OSERIX S.A.**  
83, Rue de Jumet  
B - 6041 GOSSELIES  
Belgium

Tel.: +32 (0) 71 258 634

Device Serial Number:

Distributor: